

ANUGERAH RACK

SLU

SLW

STRAIGHT LADDER U - TYPE

STRAIGHT LADDER W - TYPE

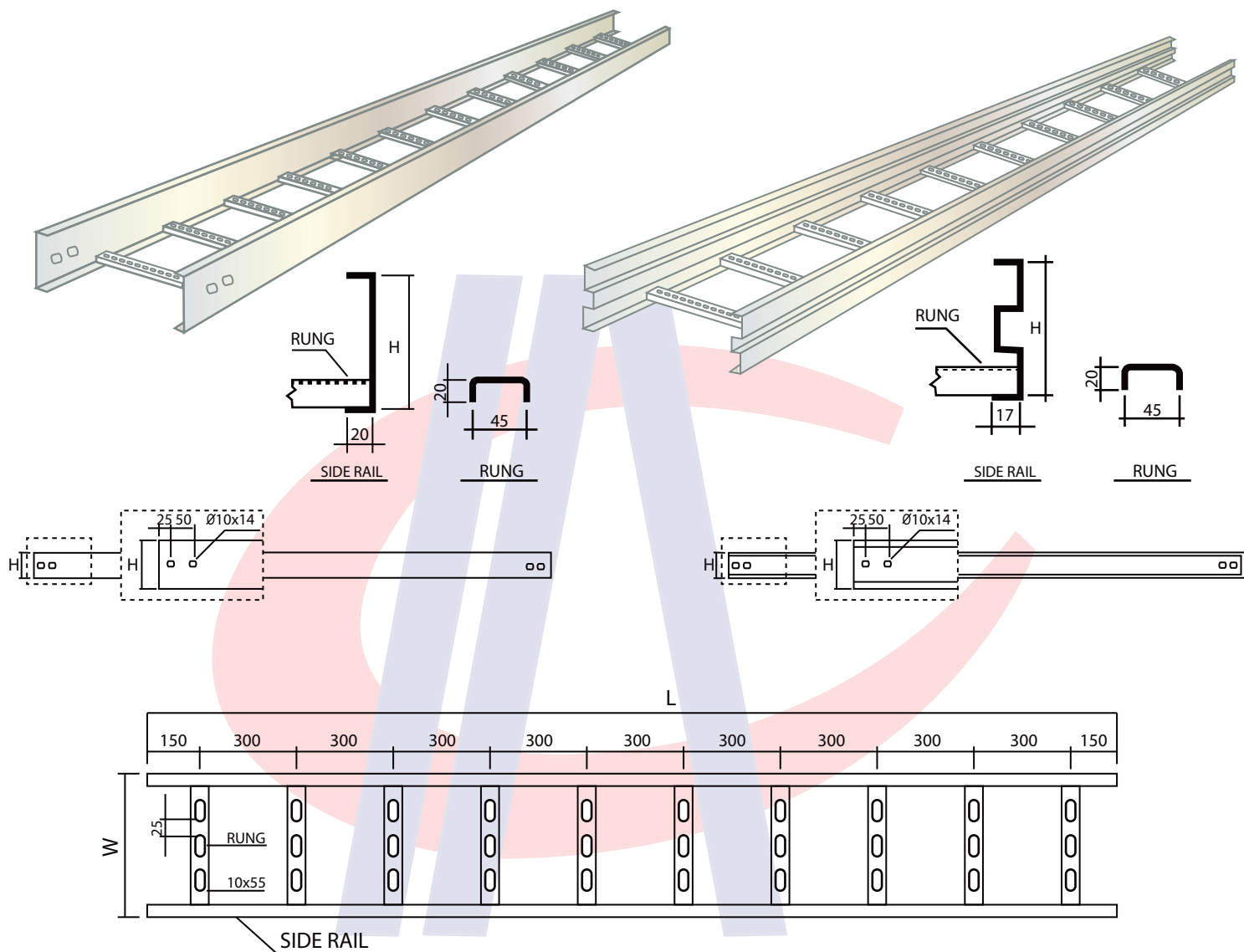

PART NO.	W	H	L
AHM/SLU/ST - 200	200	100	3000
AHM/SLU/ST - 300	300	100	3000
AHM/SLU/ST - 400	400	100	3000
AHM/SLU/ST - 500	500	100	3000
AHM/SLU/ST - 600	600	100	3000
AHM/SLU/ST - 800	800	100	3000

PART NO.	W	H	L
AHM/SLW/ST - 200	200	100	3000
AHM/SLW/ST - 300	300	100	3000
AHM/SLW/ST - 400	400	100	3000
AHM/SLW/ST - 500	500	100	3000
AHM/SLW/ST - 600	600	100	3000
AHM/SLW/ST - 800	800	100	3000

MATERIAL : HOT ROLLED SHEET STEEL (SPHC) THICKNES : 1.8 mm - 2.0 mm
 FINISHING : HOT DIP GALVANIZED (BS 729, DIN 50978) / COATING / ELECTRO GALVANIZED
 OTHER DIMENSION ARE AVAILABLE UPON SPECIAL REQUIREMENT

STRAIGHT LADDER HEAVY DUTY

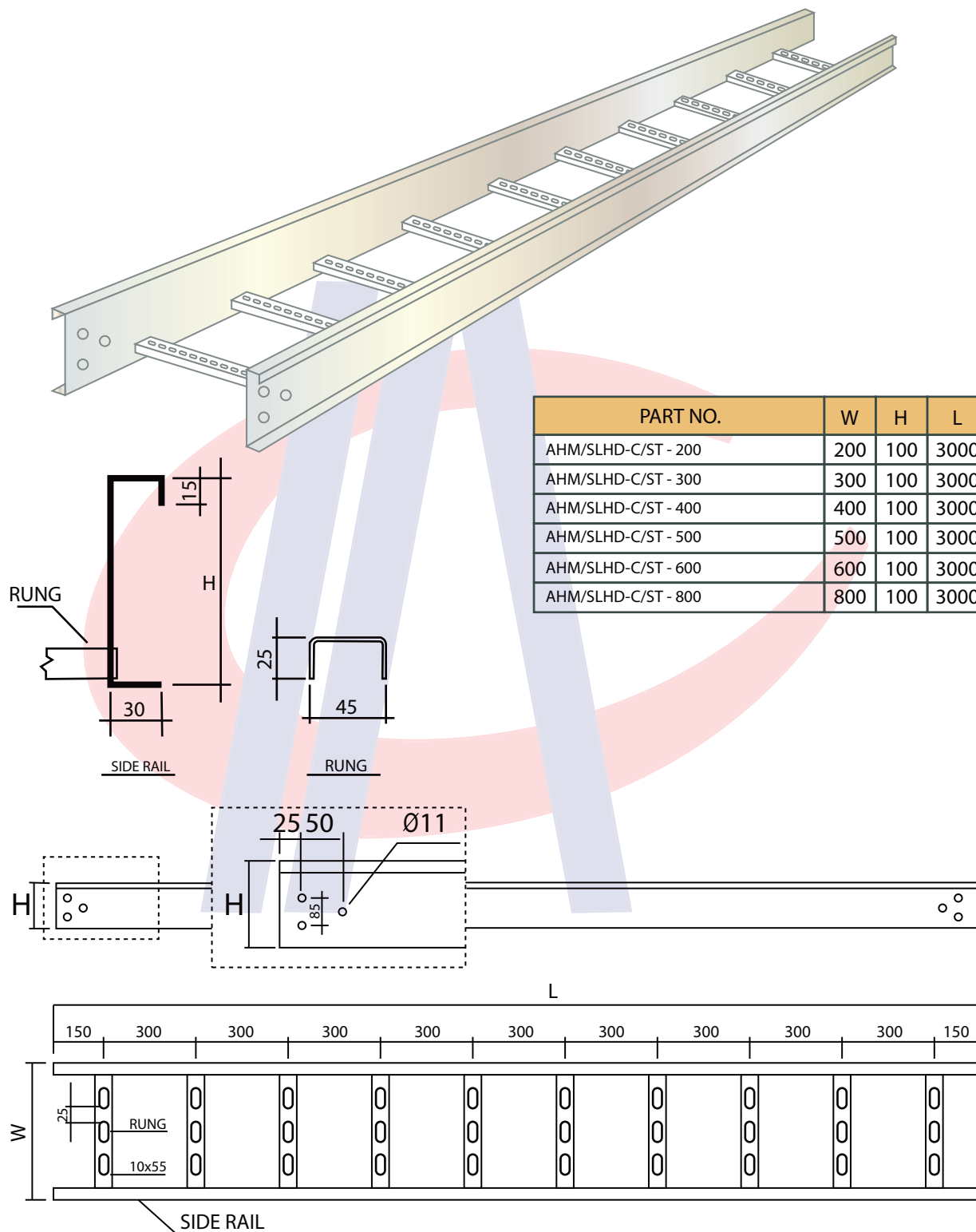

MATERIAL : HOT ROLLED SHEET STEEL (SPHC) THICKNES : 1.8 mm - 2.0 mm
 FINISHING : HOT DIP GALVANIZED (BS 729, DIN 50978) / COATING / ELECTRO GALVANIZED
 OTHER DIMENSION ARE AVAILABLE UPON SPECIAL REQUIREMENT

HORIZONTAL TEE LADDER

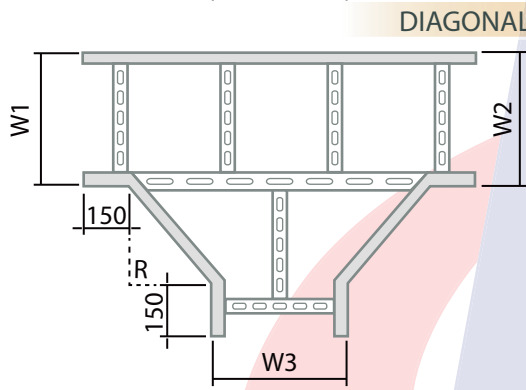
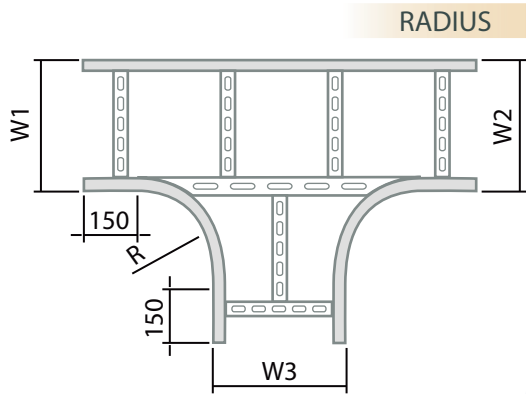

Radius Type

PART NO.	W1	W2	W3	H	R
AHM/SLU/SLW/SLHD/TEE - 200/200/200	200	200	200	100	150
AHM/SLU/SLW/SLHD/TEE - 300/300/300	300	300	300	100	150
AHM/SLU/SLW/SLHD/TEE - 400/400/400	400	400	400	100	150
AHM/SLU/SLW/SLHD/TEE - 500/500/500	500	500	500	100	150
AHM/SLU/SLW/SLHD/TEE - 600/600/600	600	600	600	100	150
AHM/SLU/SLW/SLHD/TEE - 800/800/800	800	800	800	100	150

Diagonal Type

PART NO.	W1	W2	W3	H	R
AHM/SLU/SLW/SLHD/D/TEE - 200/200/200	200	200	200	100	150
AHM/SLU/SLW/SLHD/D/TEE - 300/300/300	300	300	300	100	150
AHM/SLU/SLW/SLHD/D/TEE - 400/400/400	400	400	400	100	150
AHM/SLU/SLW/SLHD/D/TEE - 500/500/500	500	500	500	100	150
AHM/SLU/SLW/SLHD/D/TEE - 600/600/600	600	600	600	100	150
AHM/SLU/SLW/SLHD/D/TEE - 800/800/800	800	800	800	100	150

HORIZONTAL CROSS LADDER

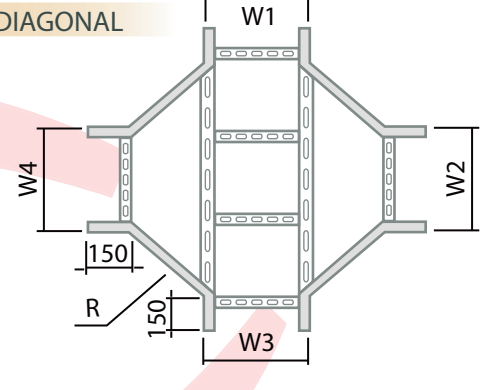
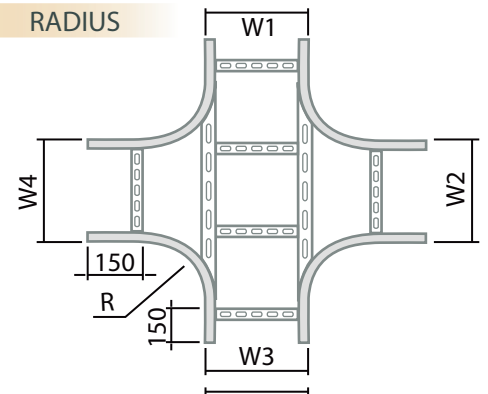

Radius Type

PART NO.	W1	W2	W3	W4	H	R
AHM/SLU/SLW/SLHD/CROSS - 200/200/200	200	200	200	200	100	150
AHM/SLU/SLW/SLHD/CROSS - 300/300/300	300	300	300	300	100	150
AHM/SLU/SLW/SLHD/CROSS - 400/400/400	400	400	400	400	100	150
AHM/SLU/SLW/SLHD/CROSS - 500/500/500	500	500	500	500	100	150
AHM/SLU/SLW/SLHD/CROSS - 600/600/600	600	600	600	600	100	150
AHM/SLU/SLW/SLHD/CROSS - 800/800/800	800	800	800	800	100	150

Diagonal Type

PART NO.	W1	W2	W3	W4	H	R
AHM/SLU/SLW/SLHD/D/CROSS - 200/200/200	200	200	200	200	100	150
AHM/SLU/SLW/SLHD/D/CROSS - 300/300/300	300	300	300	300	100	150
AHM/SLU/SLW/SLHD/D/CROSS - 400/400/400	400	400	400	400	100	150
AHM/SLU/SLW/SLHD/D/CROSS - 500/500/500	500	500	500	500	100	150
AHM/SLU/SLW/SLHD/D/CROSS - 600/600/600	600	600	600	600	100	150
AHM/SLU/SLW/SLHD/D/CROSS - 800/800/800	800	800	800	800	100	150

MATERIAL : HOT ROLLED SHEET STEEL (SPHC) THICKNES : 1.8 mm - 2.0 mm
 FINISHING : HOT DIP GALVANIZED (BS 729, DIN 50978) / COATING / ELECTRO GALVANIZED
 OTHER DIMENSION ARE AVAILABLE UPON SPECIAL REQUIREMENT

HORIZONTAL ELBOW LADDER

RADIUS

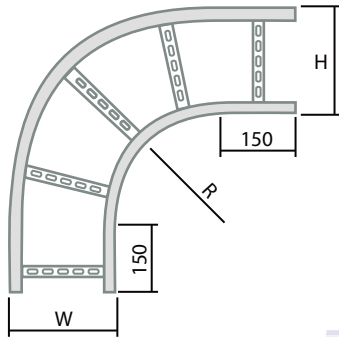

DIAGONAL

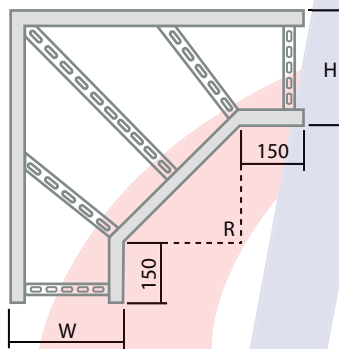

Radius Type

PART NO.	W	H	R
AHM/SLU/SLW/SLHD/ELBOW - 200	200	100	150
AHM/SLU/SLW/SLHD/ELBOW - 300	300	100	150
AHM/SLU/SLW/SLHD/ELBOW - 400	400	100	150
AHM/SLU/SLW/SLHD/ELBOW - 500	500	100	150
AHM/SLU/SLW/SLHD/ELBOW - 600	600	100	150
AHM/SLU/SLW/SLHD/ELBOW - 800	800	100	150

Radius Type

PART NO.	W	H	R
AHM/SLU/SLW/SLHD/D/ELBOW - 200	200	100	150
AHM/SLU/SLW/SLHD/D/ELBOW - 300	300	100	150
AHM/SLU/SLW/SLHD/D/ELBOW - 400	400	100	150
AHM/SLU/SLW/SLHD/D/ELBOW - 500	500	100	150
AHM/SLU/SLW/SLHD/D/ELBOW - 600	600	100	150
AHM/SLU/SLW/SLHD/D/ELBOW - 800	800	100	150

REDUCER LADDER

CENTER REDUCER

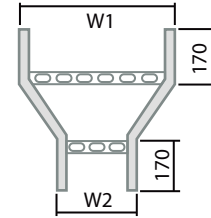

LEFT HAND REDUCER

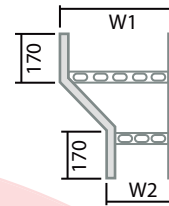

RIGHT HAND REDUCER

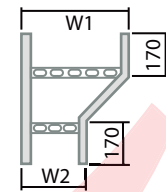

Center Reducer

PART NO.	W1	W2	H
AHM/SLU/SLW/SLHD/REDUCER - 300/200	300	200	100
AHM/SLU/SLW/SLHD/REDUCER - 400/200	400	200	100
AHM/SLU/SLW/SLHD/REDUCER - 500/300	500	300	100
AHM/SLU/SLW/SLHD/REDUCER - 600/300	600	300	100
AHM/SLU/SLW/SLHD/REDUCER - 600/400	600	400	100
AHM/SLU/SLW/SLHD/REDUCER - 800/400	800	400	100
AHM/SLU/SLW/SLHD/REDUCER - 800/600	800	600	100

Left Hand & Right Hand Reducer

PART NO.	W1	W2	H
AHM/SLU/SLW/SLHD/REDUCER - 300/200	300	200	100
AHM/SLU/SLW/SLHD/REDUCER - 400/200	400	200	100
AHM/SLU/SLW/SLHD/REDUCER - 500/300	500	300	100
AHM/SLU/SLW/SLHD/REDUCER - 600/300	600	300	100
AHM/SLU/SLW/SLHD/REDUCER - 600/400	600	400	100
AHM/SLU/SLW/SLHD/REDUCER - 800/400	800	400	100
AHM/SLU/SLW/SLHD/REDUCER - 800/600	800	600	100

MATERIAL : HOT ROLLED SHEET STEEL (SPHC) THICKNES : 1.8 mm - 2.0 mm
 FINISHING : HOT DIP GALVANIZED (BS 729, DIN 50978) / COATING / ELECTRO GALVANIZED
 OTHER DIMENSION ARE AVAILABLE UPON SPECIAL REQUIREMENT

INSIDE/OUTSIDE RISER LADDER

INSIDE RISER

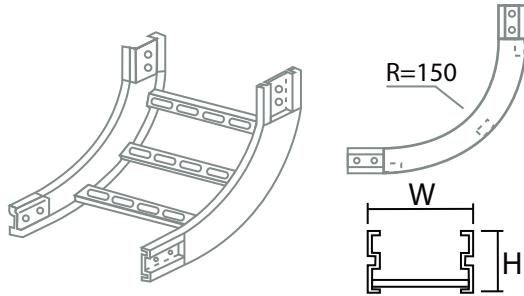

INSIDE RISER

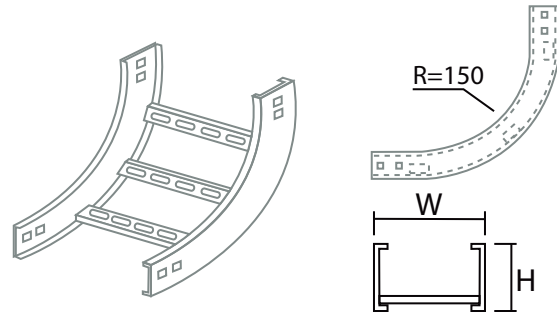

OUTSIDE RISER

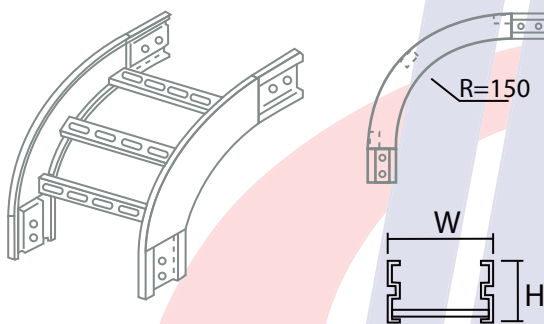

OUTSIDE RISER

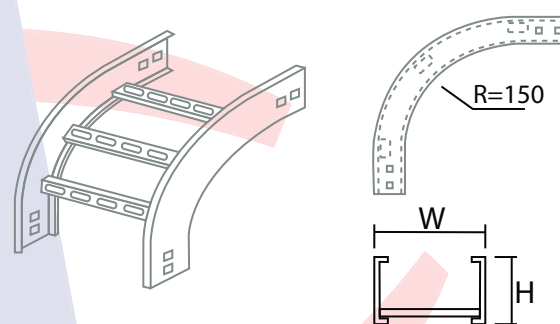

Inside Riser & Outside Riser

CODE	W	H
AHM/SLW/IR/OR	100	100
AHM/SLW/IR/OR	200	100
AHM/SLW/IR/OR	300	100
AHM/SLW/IR/OR	400	100
AHM/SLW/IR/OR	500	100
AHM/SLW/IR/OR	600	100
AHM/SLW/IR/OR	700	100
AHM/SLW/IR/OR	800	100
AHM/SLW/IR/OR	900	100
AHM/SLW/IR/OR	1000	100

Inside Riser & Outside Riser

CODE	W	H
AHM/SLU/IR/OR	100	100
AHM/SLU/IR/OR	200	100
AHM/SLU/IR/OR	300	100
AHM/SLU/IR/OR	400	100
AHM/SLU/IR/OR	500	100
AHM/SLU/IR/OR	600	100
AHM/SLU/IR/OR	700	100
AHM/SLU/IR/OR	800	100
AHM/SLU/IR/OR	900	100
AHM/SLU/IR/OR	1000	100

MATERIAL : HOT ROLLED SHEET STEEL (SPHC) THICKNES : 1.8 mm - 2.0 mm
 FINISHING : HOT DIP GALVANIZED (BS 729, DIN 50978) / COATING / ELECTRO GALVANIZED
 OTHER DIMENSION ARE AVAILABLE UPON SPECIAL REQUIREMENT

ANUGERAH RACK

STC

STU

STRAIGHT TRAY C - TYPE

STRAIGHT TRAY U - TYPE

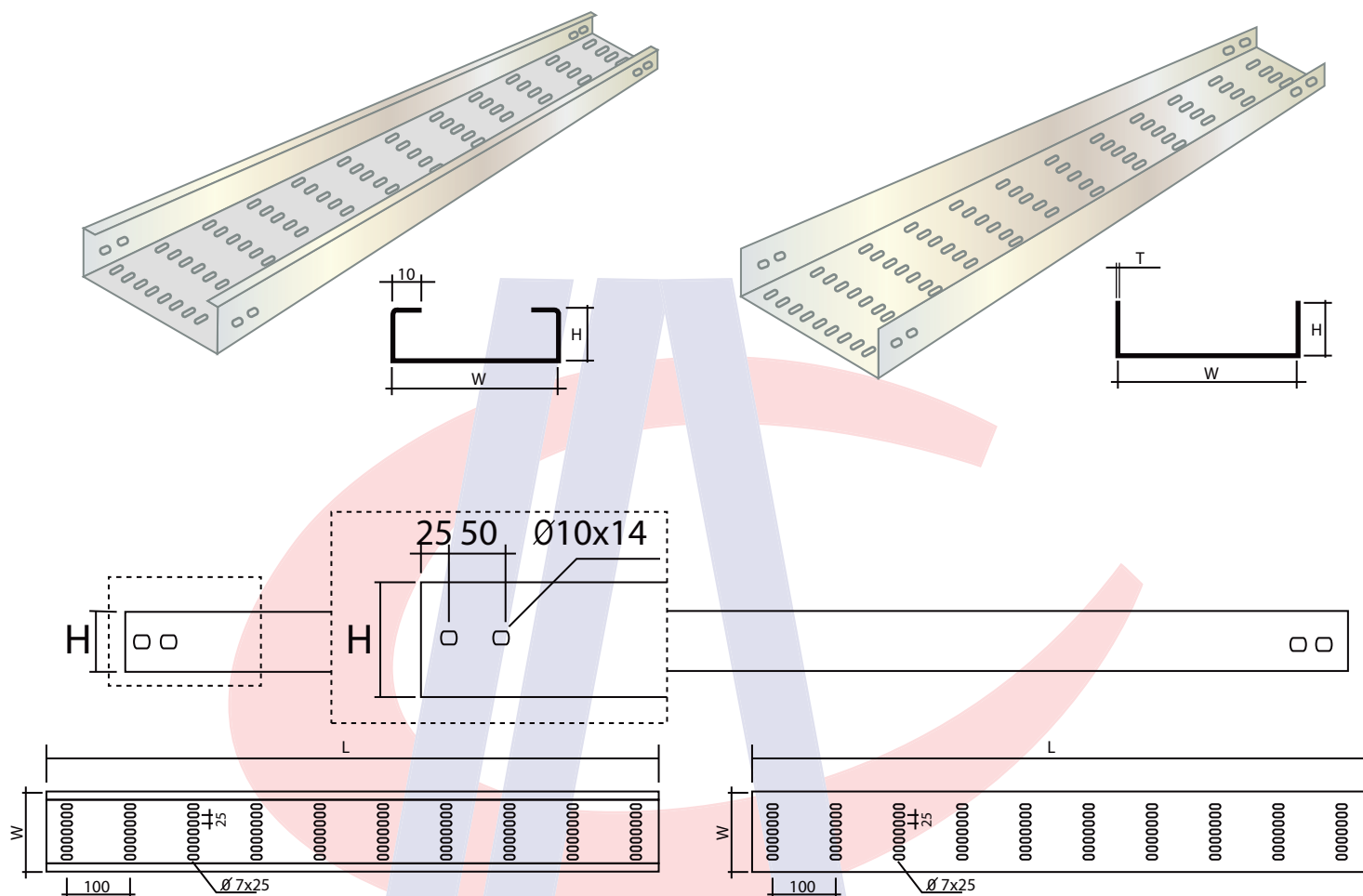

PART NO.	W	H	L
AHM/STC/TRAY - 100	100	50	3000
AHM/STC/TRAY - 200	200	50	3000
AHM/STC/TRAY - 300	300	50	3000
AHM/STC/TRAY - 400	400	50	3000
AHM/STC/TRAY - 500	500	50	3000
AHM/STC/TRAY - 600	600	50	3000
AHM/STC/TRAY - 200	200	100	3000
AHM/STC/TRAY - 300	300	100	3000
AHM/STC/TRAY - 400	400	100	3000
AHM/STC/TRAY - 500	500	100	3000
AHM/STC/TRAY - 600	600	100	3000

PART NO.	W	L
AHM/STU/TRAY - 100	100	3000
AHM/STU/TRAY - 200	200	3000
AHM/STU/TRAY - 300	300	3000
AHM/STU/TRAY - 400	400	3000
AHM/STU/TRAY - 500	500	3000
AHM/STU/TRAY - 600	600	3000
AHM/STU/TRAY - 200	200	3000
AHM/STU/TRAY - 300	300	3000
AHM/STU/TRAY - 400	400	3000
AHM/STU/TRAY - 500	500	3000
AHM/STU/TRAY - 600	600	3000

MATERIAL : HOT ROLLED SHEET STEEL (SPHC) THICKNES : 1.8 mm - 2.0 mm
 FINISHING : HOT DIP GALVANIZED (BS 729, DIN 50978) / COATING / ELECTRO GALVANIZED
 OTHER DIMENSION ARE AVAILABLE UPON SPECIAL REQUIREMENT

ELBOW TRAY (RADIUS)

ELBOW TRAY (RADIUS)

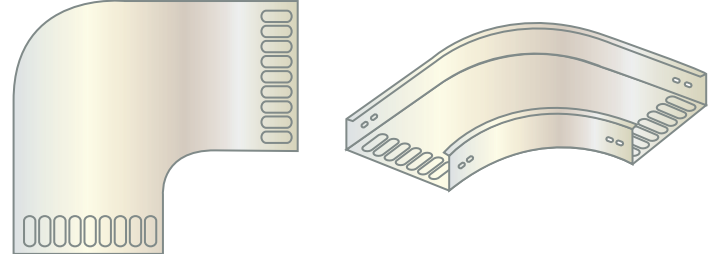
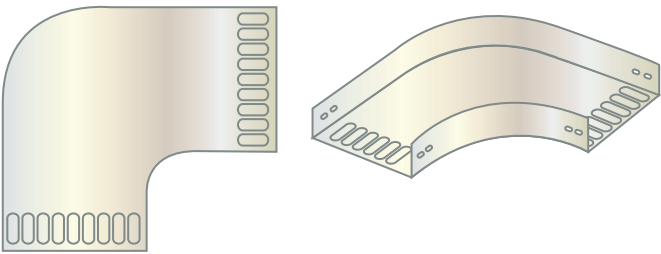

ELBOW TRAY (DIAGONAL)

ELBOW TRAY (DIAGONAL)

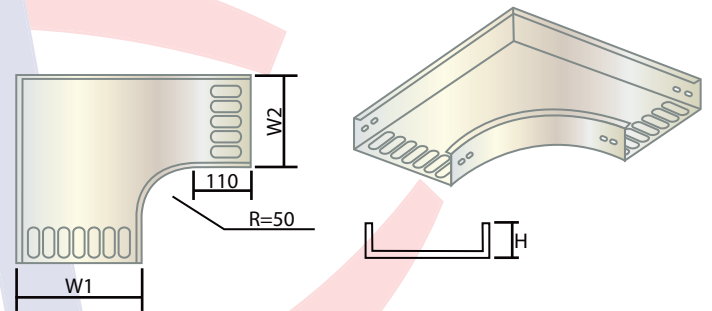
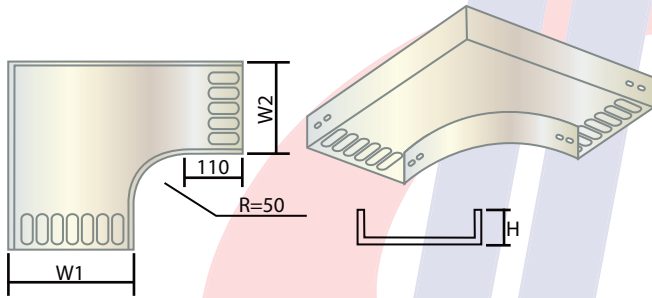

PART NO.	W1	W2	R
AHM/STU/ELBOW	100	100	50
AHM/STU/ELBOW	200	200	50
AHM/STU/ELBOW	300	300	50
AHM/STU/ELBOW	400	400	50
AHM/STU/ELBOW	500	500	50
AHM/STU/ELBOW	600	600	50
AHM/STU/ELBOW	700	700	50
AHM/STU/ELBOW	800	800	50
AHM/STU/ELBOW	900	900	50
AHM/STU/ELBOW	1000	1000	50

MATERIAL : HOT ROLLED SHEET STEEL (SPHC) THICKNES : 1.8 mm - 2.0 mm
 FINISHING : HOT DIP GALVANIZED (BS 729, DIN 50978) / COATING / ELECTRO GALVANIZED
 OTHER DIMENSION ARE AVAILABLE UPON SPECIAL REQUIREMENT

TEE TRAY

CROSS TRAY

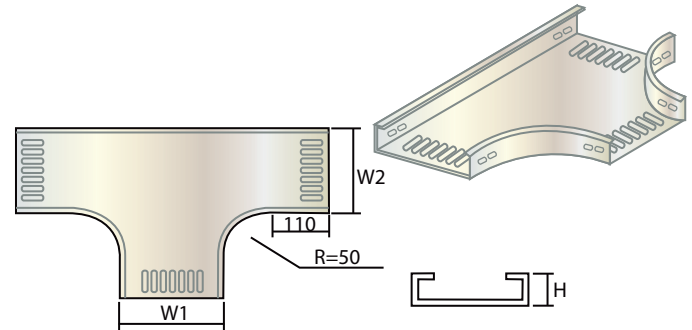
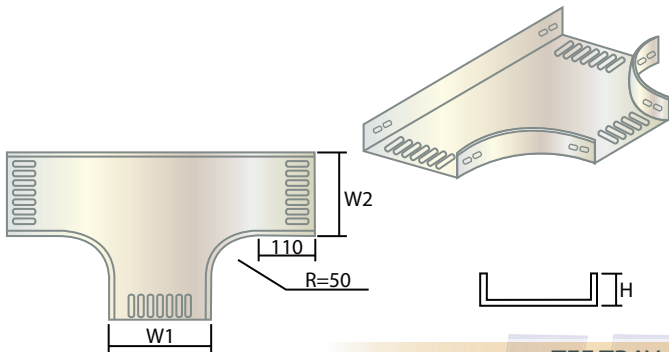

TEE TRAY

CROSS TRAY

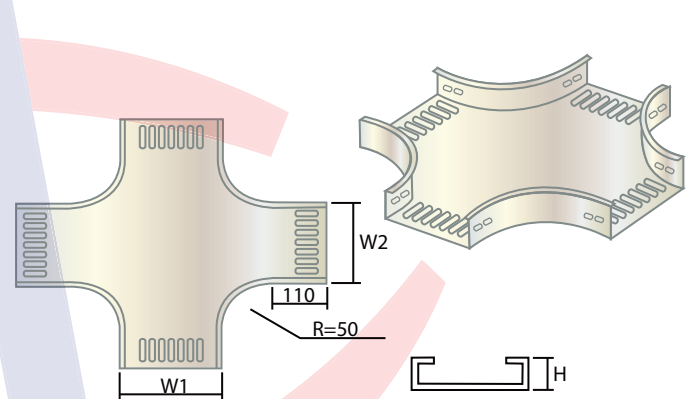
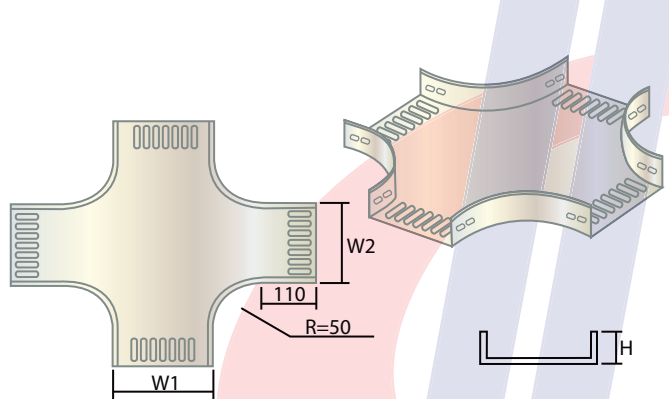

PART NO.	W1	W2	R
AHM/STU/TEE	100	100	50
AHM/STU/TEE	200	200	50
AHM/STU/TEE	300	300	50
AHM/STU/TEE	400	400	50
AHM/STU/TEE	500	500	50
AHM/STU/TEE	600	600	50
AHM/STU/TEE	700	700	50
AHM/STU/TEE	800	800	50
AHM/STU/TEE	900	900	50
AHM/STU/TEE	1000	1000	50

PART NO.	W1	W2	R
AHM/STU/CROSS	100	100	50
AHM/STU/CROSS	200	200	50
AHM/STU/CROSS	300	300	50
AHM/STU/CROSS	400	400	50
AHM/STU/CROSS	500	500	50
AHM/STU/CROSS	600	600	50
AHM/STU/CROSS	700	700	50
AHM/STU/CROSS	800	800	50
AHM/STU/CROSS	900	900	50
AHM/STU/CROSS	1000	1000	50

MATERIAL : HOT ROLLED SHEET STEEL (SPHC) THICKNES : 1.8 mm - 2.0 mm
 FINISHING : HOT DIP GALVANIZED (BS 729, DIN 50978) / COATING / ELECTRO GALVANIZED
 OTHER DIMENSION ARE AVAILABLE UPON SPECIAL REQUIREMENT

HORIZONTAL ELBOW LADDER

REDUCER LADDER

Straight Reducer

Straight Reducer

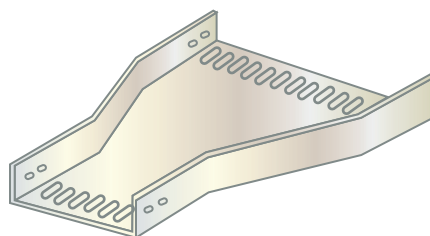
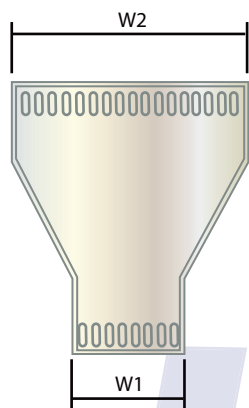

Offset Reducer

Offset Reducer

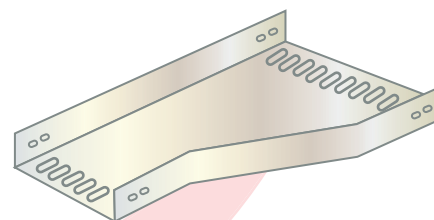
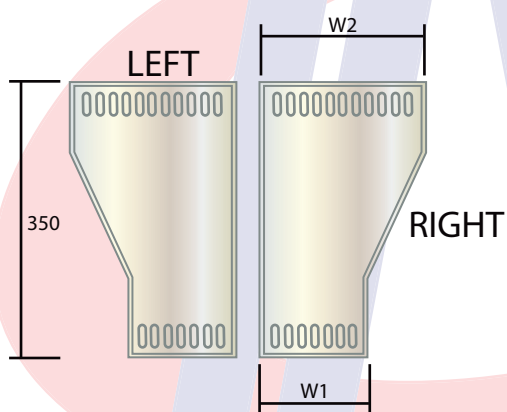

PART NO.	W1	W2
AHM/STC/STU/REDUCER	100	200
AHM/STC/STU/REDUCER	200	300
AHM/STC/STU/REDUCER	300	400
AHM/STC/STU/REDUCER	400	500
AHM/STC/STU/REDUCER	500	600
AHM/STC/STU/REDUCER	600	700
AHM/STC/STU/REDUCER	700	800
AHM/STC/STU/REDUCER	800	900
AHM/STC/STU/REDUCER	900	1000

MATERIAL : HOT ROLLED SHEET STEEL (SPHC) THICKNES : 1.8 mm - 2.0 mm
 FINISHING : HOT DIP GALVANIZED (BS 729, DIN 50978) / COATING / ELECTRO GALVANIZED
 OTHER DIMENSION ARE AVAILABLE UPON SPECIAL REQUIREMENT

INSIDE & OUTSIDE RISER

RADIUS

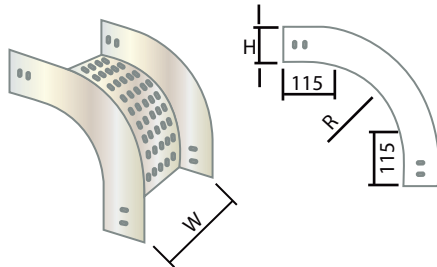

RADIUS

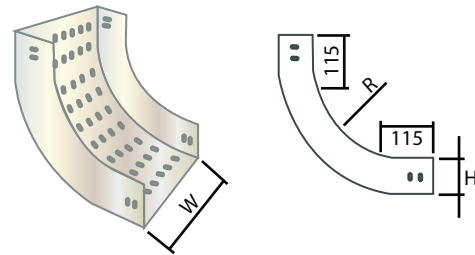

DIAGONAL

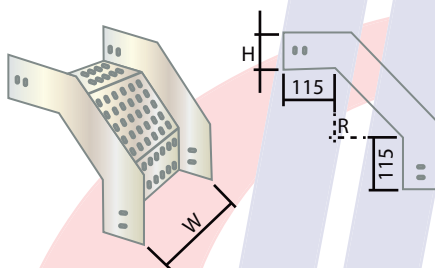

DIAGONAL

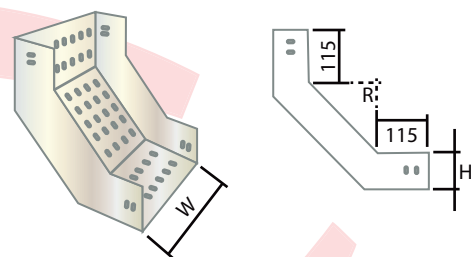

PART NO.	W	R
AHM/STU/OR/IR - 100	100	75
AHM/STU/OR/IR - 200	200	75
AHM/STU/OR/IR - 300	300	75
AHM/STU/OR/IR - 400	400	75
AHM/STU/OR/IR - 500	500	75
AHM/STU/OR/IR - 600	600	75

MATERIAL : HOT ROLLED SHEET STEEL (SPHC) THICKNES : 1.8 mm - 2.0 mm
 FINISHING : HOT DIP GALVANIZED (BS 729, DIN 50978) / COATING / ELECTRO GALVANIZED
 OTHER DIMENSION ARE AVAILABLE UPON SPECIAL REQUIREMENT

INSIDE & OUTSIDE RISER

RADIUS

RADIUS

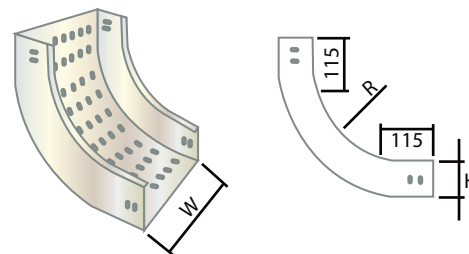
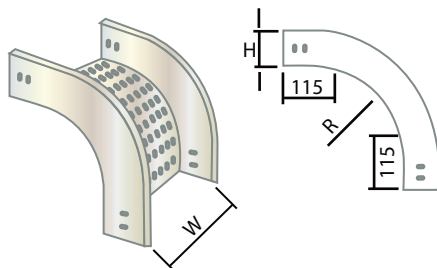

DIAGONAL

DIAGONAL

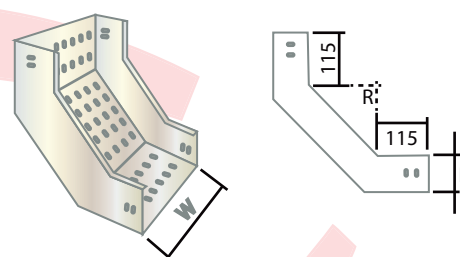
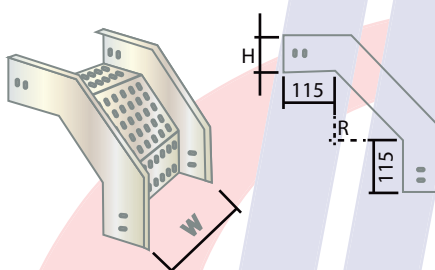

PART NO.	W	R
AHM/STC/OR/IR - 100	100	75
AHM/STC/OR/IR - 200	200	75
AHM/STC/OR/IR - 300	300	75
AHM/STC/OR/IR - 400	400	75
AHM/STC/OR/IR - 500	500	75
AHM/STC/OR/IR - 600	600	75

MATERIAL : HOT ROLLED SHEET STEEL (SPHC) THICKNES : 1.8 mm - 2.0 mm
 FINISHING : HOT DIP GALVANIZED (BS 729, DIN 50978) / COATING / ELECTRO GALVANIZED
 OTHER DIMENSION ARE AVAILABLE UPON SPECIAL REQUIREMENT

JOINT SET

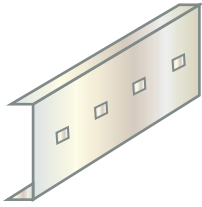

JS - STC
JS - SLU

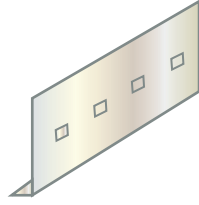

JS - STU

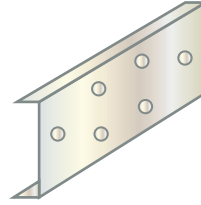

JS - SLHD

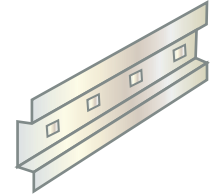

JS - SLW

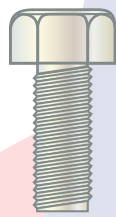

HEX BOLT M8 x 20



WASHER



NUT

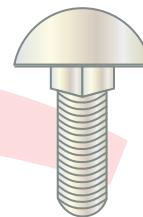

ROUNDHEAD 3/8 x 3/4

FISH PLATE SET

HORIZONTAL FISH PLATE

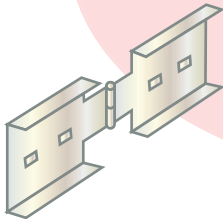

HF-STC, HF-SLU

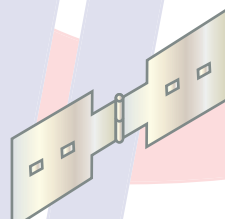

HF - STU

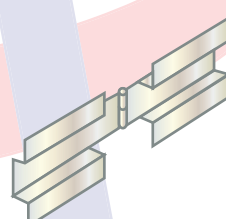

HF - SLW

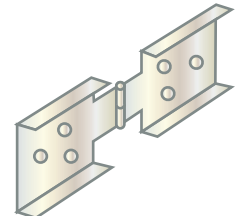

HF - SLHD

VERTICAL FISH PLATE

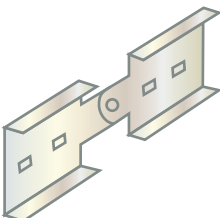

VF-STC, VF-SLU

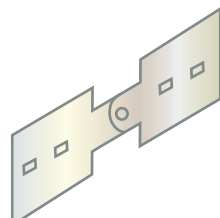

VF - STU

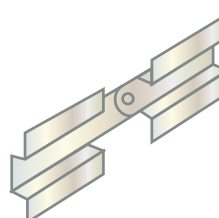

VF - STW

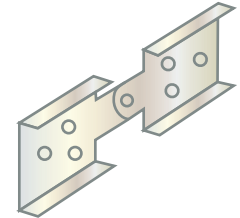

VF - SLHD

MATERIAL : HOT ROLLED SHEET STEEL (SPHC) THICKNES : 1.8 mm - 2.0 mm
 FINISHING : HOT DIP GALVANIZED (BS 729, DIN 50978) / COATING / ELECTRO GALVANIZED
 OTHER DIMENSION ARE AVAILABLE UPON SPECIAL REQUIREMENT

BRACKET SUPPORT

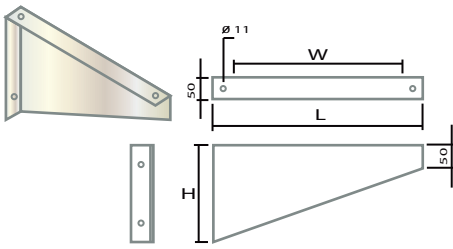

PART NO.	W	L	H
AHM/BS	100	150	150
AHM/BS	200	250	150
AHM/BS	300	350	150
AHM/BS	400	450	200
AHM/BS	500	550	200
AHM/BS	600	650	200
AHM/BS	800	850	200

HANGER BEAM

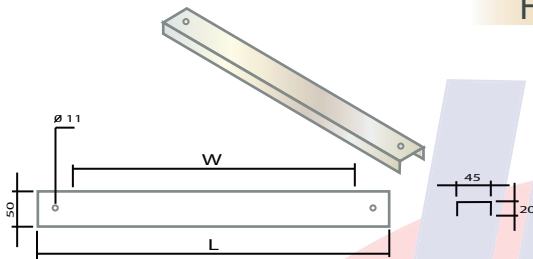

PART NO.	W	L
AHM/HB	100	150
AHM/HB	200	250
AHM/HB	300	350
AHM/HB	400	450
AHM/HB	500	550
AHM/HB	600	650
AHM/HB	800	850

HANGER ROD

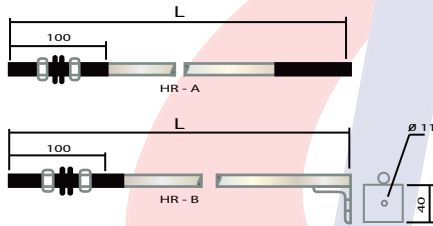

PART NO.	DIAMETER	L
HR - A	10mm OR SPECIAL REQUIREMEN	AVAILABLE 1, 1.5, 2m OR SPECIAL REQUIREMEN
HR - B		

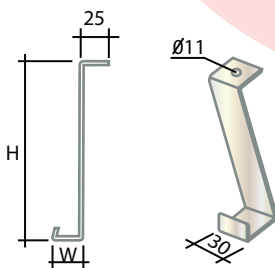

HOLD DOWN CLAMP

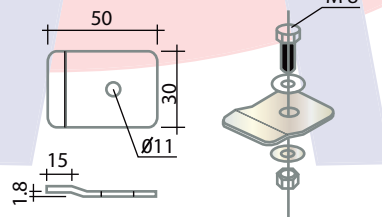

HOLD DOWN CLIP

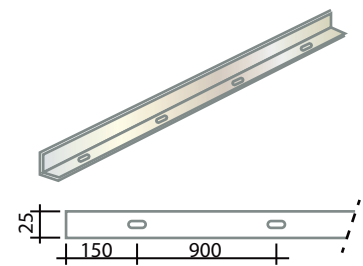

STRAIGHT SEPARATOR

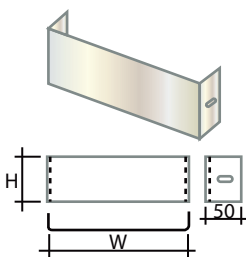

END PLATE SET

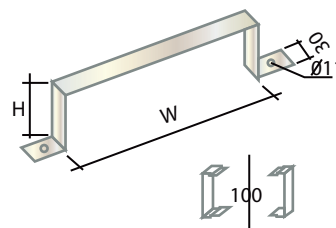

COVER CLAMP & COVER CLIP

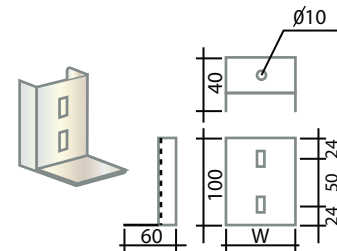

SPLICE PLATE SET

MATERIAL : HOT ROLLED SHEET STEEL (SPHC) THICKNES : 1.8 mm - 2.0 mm
 FINISHING : HOT DIP GALVANIZED (BS 729, DIN 50978) / COATING / ELECTRO GALVANIZED
 OTHER DIMENSION ARE AVAILABLE UPON SPECIAL REQUIREMENT

INSTALLATION ACCESORIES

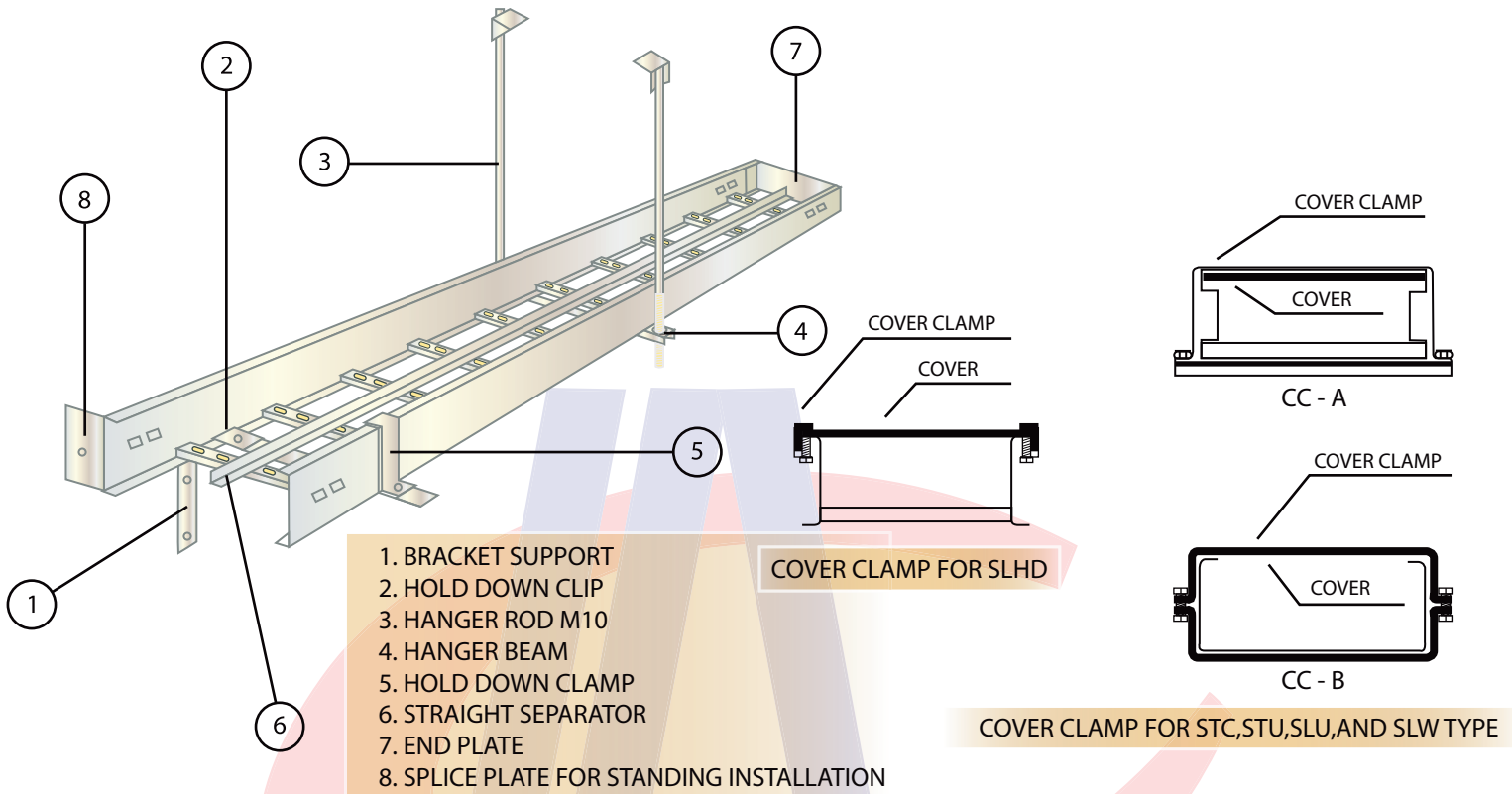

COVER

STRAIGHT COVER

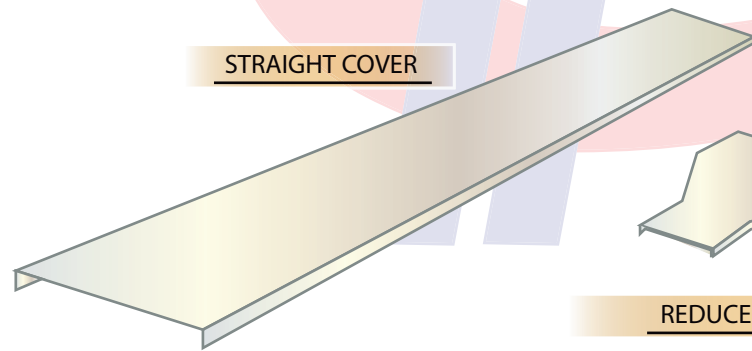

REDUCER COVER

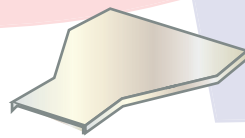

CROSS COVER

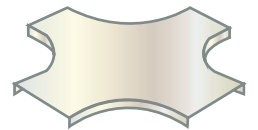
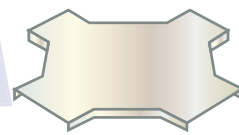

TEE COVER

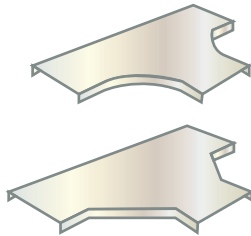

ELBOW COVER

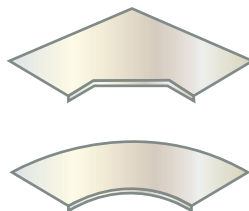

RISER COVER

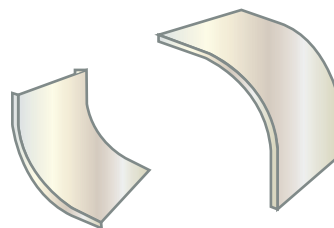

RISER COVER

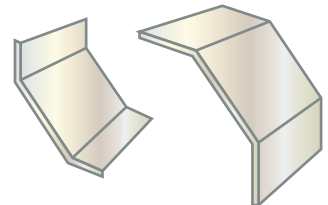

MATERIAL : HOT ROLLED SHEET STEEL (SPHC) THICKNES : 1.8 mm - 2.0 mm
 FINISHING : HOT DIP GALVANIZED (BS 729, DIN 50978) / COATING / ELECTRO GALVANIZED
 OTHER DIMENSION ARE AVAILABLE UPON SPECIAL REQUIREMENT